

SANGALO

PATTA[®]

www.sangalofijaciones.com.ar



SANGALO

SOMOS DISTRIBUIDOR OFICIAL DE:

PATTA®

- En este Catálogo encontrará nuestra oferta de productos PATTA.
- Consúltenos por cualquier duda respecto de los mismos, a la brevedad nos comunicaremos con Ud.

VÍAS DE CONTACTO PARA CLIENTES:

clientes@sangalofijaciones.com.ar



11 7663-5274



Amplios depósitos



Atención y Servicio



Ágil entrega

www.sangalofijaciones.com.ar

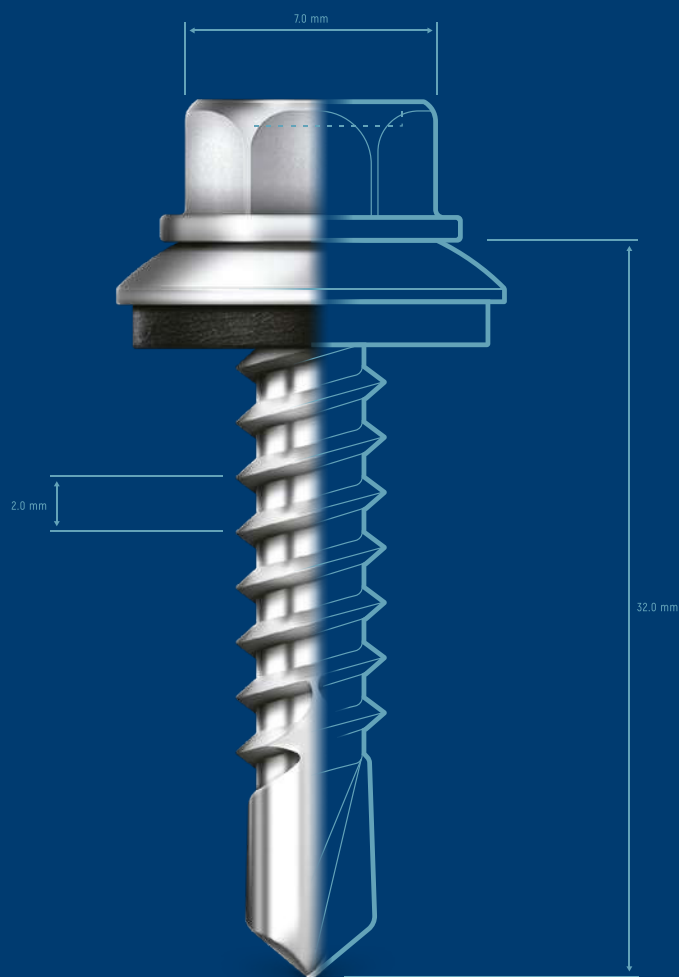

PATTA®

Grip Forever

Our components, your key



SANGALO
DISTRIBUIDOR OFICIAL

PATTA®

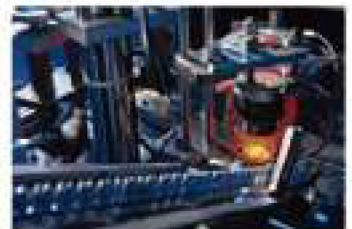

SANGALO
DISTRIBUIDOR OFICIAL

PATTA[®]

Certificados

La garantía de calidad es nuestra promesa para cada cliente.

ISO 9001



ISO 9001



ISO 14001



CE Marking



TS 16949



Indice

AUTOPERFORANTES PUNTA MECHA

AUTOPERFORANTE CABEZA HEXAGONAL PUNTA MECHA - F1



08 y 09

AUTOPERFORANTE CABEZA FLANGEADA PUNTA MECHA - F5



09

AUTOPERFORANTE CABEZA FRESADA PUNTA MECHA CON ASAS - F8



10

AUTOPERFORANTE CABEZA FRESADA PUNTA MECHA - F9



11

AUTOPERFORANTE CABEZA FIJADORA PUNTA MECHA - F7



12

AUTOPERFORANTE CABEZA TROMPETA PUNTA MECHA - F13



13

AUTOPERFORANTE PAN FRAMING PUNTA MECHA - F10



13

AUTOPERFORANTE PUNTA MECHA Y PUNTA AGUJA

07

TORNILLOS INFORMACIÓN GENERAL

06

PATEK



25



SANGALO
DISTRIBUIDOR OFICIAL

PATTA[®]

AUTOPERFORANTES PUNTA AGUJA

TORNILLO FIXER - E2



14 y 17

AUTOPERFORANTE CAB. TROMPETA PUNTA AGUJA ROSCA GRUESA F2



18

AUTOPERFORANTE CAB. TROMPETA PUNTA AGUJA ROSCA FINA F3



19

AUTOPERFORANTE PAN FRAMING PUNTA AGUJA - F11



19

AUTOPERFORANTE CABEZA FLANGEADA PUNTA AGUJA - F6



20

AUTOPERFORANTE CABEZA HEXAGONAL (T17) RANURADO - F4



20

TORNILLO PARKER CABEZA FIJADORA - E4



21

TORNILLO CABEZA TANQUE -E3



22

HORMIGON

AUTOPERFORANTE CABEZA TORX / CONCRETO - F12



24

PACON



26

Diagrama de aplicación

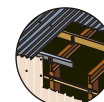

15 y 16

Accesorios

Puntas y Casquillos



23



TORNILLOS INFORMACIÓN GENERAL

TIPOS DE CABEZAS



FIJADORA



TROMPETA



PAN FRAMING



HEXAGONAL



FRESADO



FLANGEADA

CABEZA

BAJO CABEZA



PHILLIPS



TORX



PHILLIPS 4 RANURAS



HEXAGONAL



HEXAGONAL FLANGE

ROSCAS

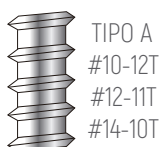

TIPO A
#10-12T
#12-11T
#14-10T

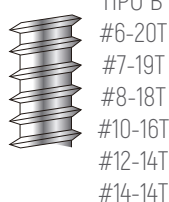

TIPO B
#6-20T
#7-19T
#8-18T
#10-16T
#12-14T
#14-14T

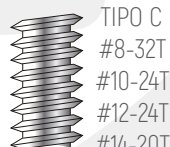

TIPO C
#8-32T
#10-24T
#12-24T
#14-20T



ALTO-BAJO

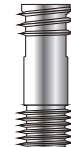

DOBLE ROSCA

PUNTAS

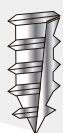

TIPO 17

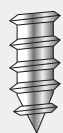

STANDARD



MECHAS CON ALAS



PT. #1



PT. #2



PT. #3



PT. #4



PT. #5



PT. #6

PUNTA MECHA

ARANDELA

VULCANIZADA



#10, #12, #14



#10, #12, #14



#10 x 14
#12 x 14



#12 x 16
#14 x 16



#12 x 19
#14 x 19



#14 x 25

ZINCADO

YZ: Zincado Amarillo

ZN: Zincado Azul

BZ: Zincado Negro



SANGALO
DISTRIBUIDOR OFICIAL

PATTA®

Autoperforantes Punta Mecha



F1
Autoperforante Cabeza Hexagonal Punta Mecha



F5
Autoperforante Cabeza Flangeada Punta Mecha



F8
Autoperforante Cabeza Hexagonal Punta Mecha con alas



F9
Autoperforante Cabeza Fresada Punta Mecha



F7
Autoperforante Cabeza Fijadora Punta Mecha



F12
Autoperforante Cabeza Trompeta Punta Mecha



F10
Autoperforante Pan Fram Punta Mecha



PATEK

Autoperforantes Punta Aguja



E2
Tornillo Fixer



F2
Autoperforante Cabeza Trompeta Aguja Rosca Gruesa



F3
Autoperforante Cabeza Trompeta Punta Aguja Rosca Fina



F11
Autoperforante Pan Fram Punta Aguja



F6
Autoperforante Cabeza Flangeada Punta Aguja



F4
Autoperforante Cabeza Hexagonal T17 Ranurado



E4
Tornillo Parker



E3
Tornillo Tanque

HORMIGÓN



F13
Autoperforante Cabeza Torx/Concreto



PACON



PUNTA



CASQUILLOS

AUTOPERFORANTE CABEZA HEXAGONAL PUNTA MECHA (F1)

Aplicaciones

- Fijación de metal a madera o plástico
- Fijación de elementos metálicos entre sí y estructuras de metal
- Para fines de trabajo liviano (#8 y #10)
- Para fines de trabajo pesado (#12 y #14)
- Sujeción para estructuras o barras de viguetas
- Construcción en seco (Steel Framing) para Durlok
- Para punta Hex Magnética (1/4 - 5/16 - 3/8)

Características

- Diseñado para una perforación rápida con menor esfuerzo
- Con arandela cóncava vulcanizada (impermeabilizante)
- Acabado Zincado azul
- Punta mecha: taladra directamente el material sin necesidad de taladro previo.
- Cementado

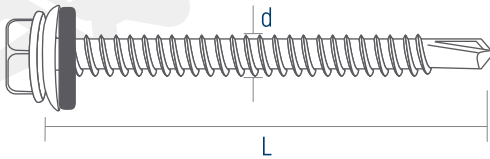

Plated

ZN

YZ

SS

Point

2

3

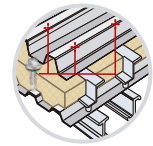
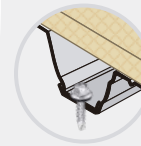

Punta #2 sugerida para aplicaciones de espesor < 2mm

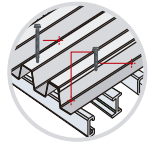

Punta #3 sugerida para aplicaciones de espesor < 5mm

Medida	Diam.	Largo	Drill Point	P Tub Hex	PIEZAS/CAJA	CAJA/GRANEL	GRANEL/PALLET	KG/PALLET
8 x 1/2	4.2	12.7	#2	1/4	1000	6	24	400
8 x 3/4	4.2	19	#2	1/4	1000	6	24	400
8 x 1	4.2	25	#2	1/4	1000	6	24	400
8 x 1 1/2	4.2	38	#2	1/4	500	6	24	400
10 x 3/4	4.8	19	#2	5/16	1000	6	24	545
10 x 1	4.8	25	#3	5/16	500	8	24	424
10 x 1 1/2	4.8	38	#3	5/16	500	6	24	396
10 x 2	4.8	50	#3	5/16	500	6	24	400
12 x 3/4	5.5	19	#3	5/16	500	8	24	400
12 x 1	5.5	25	#3	5/16	500	8	24	533
12 x 1 1/2	5.5	38	#3	5/16	500	6	24	505
12 x 2	5.5	50	#3	5/16	250	8	24	415
12 x 2 1/2	5.5	63	#3	5/16	250	6	24	365
12 x 3	5.5	76	#3	5/16	200	6	24	334
12 x 4	5.5	100	#3	5/16	200	6	24	400



SANGALO
DISTRIBUIDOR OFICIAL

PATTA®

AUTOPERFORANTE CABEZA HEXAGONAL PUNTA MECHA (F1)

Medida	Diam.	Long.	Drill Point	P Tub Hex	PIEZAS/CAJA	CAJA/GRANEL	GRANEL/PALLET	KG/PALLET
14 x 3/4	6.3	19	#3	3/8	500	6	40	528
14 x 1	6.3	25	#3	3/8	500	6	24	504
14 x 1 1/2	6.3	38	#3	3/8	300	8	24	550
14 x 2	6.3	50	#3	3/8	250	8	24	553
14 x 2 1/2	6.3	63	#3	3/8	250	6	24	400
14 x 3	6.3	76	#3	3/8	200	6	24	453
14 x 3 1/2	6.3	90	#3	3/8	150	6	24	432
14 x 4	6.3	100	#3	3/8	150	6	24	425
14 x 5	6.3	125	#3	3/8	100	8	24	400
14 x 6	6.3	155	#3	3/8	100	6	24	400

AUTOPERFORANTE CABEZA FLANGEADA PUNTA MECHA (F5)

Aplicaciones

- Estructura de acero residencial
- Ideal para ensamblaje de chapa, perfiles de chapa, aluminio, durlock, policarbonato, etc.
- Construcción en seco (Steel Framing)
- Para punta PH2 X25/X50

Características

- Punta mecha: taladra directamente el material sin necesidad de taladro previo.
- Autoroscante con altura de cabeza reducida
- Acabado estético, zincado azul
- Rosca completa
- La punta del tornillo no se desplaza

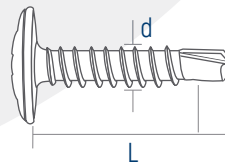

Plated
ZN **BP** **SS** Point
2

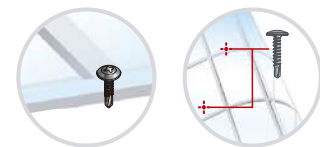

Punta #2 sugerida para aplicaciones de grosor < 2mm

Medida	Largo (inch)	Largo (mm)	Drill Point (m/m)	Drill Capacity (m/m)	PCS/BOX	BOX/CTN	CTN/PLT	PLT(KG) (G.W.)
#8-18 M4.2	1/2"	12,7	#2	1.0 - 2.0	1000	8	40	451
	5/8"	16	#2	1.0 - 2.0	1000	8	40	476
	3/4"	19	#2	1.0 - 2.0	1000	12	24	529
	1"	25	#2	1.0 - 2.0	1000	8	24	414
	1-1/4"	32	#2	1.0 - 2.0	1000	8	24	476
	1-1/2"	38	#2	1.0 - 2.0	1000	6	24	466



SS Stainless Steel
YZ Yellow Zinc
BP Black phosphate
RS Ruspert
ZN Zinc

AUTOPERFORANTE CABEZA FRESADA PUNTA MECHA CON ASAS (F8)

Aplicaciones

- Perfiles metálicos unidos a diferentes placas entre si como MDF, laminados, fenólicos y placas de revestimientos cementicios en construcción.
- Para punta PH2 X25/X50

Características

- Sujetadores con alas especiales fresan un agujero en la madera para evitar el enganche de la rosca durante la perforación
- Estrias bajo cabeza que actúan sobre el material de manera que la cabeza queda al ras para su posterior terminación
- Acabado zincado azul
- Punta mecha: taladra directamente el material sin necesidad de taladro previo.

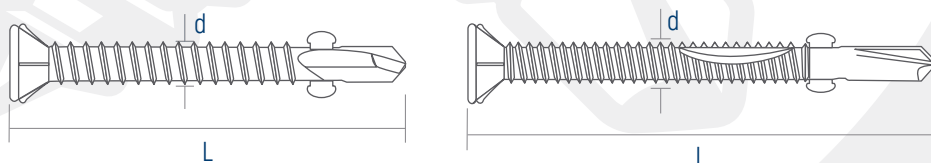

Plated

ZN

YZ

SS

Point

3

4

5

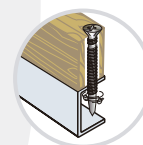
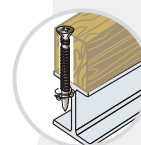

Puntas sugeridas en relación al grosor
 punta #3 < 2-5mm
 punta #4 < 5-8mm
 punta #5 < 9-12mm

Medida	Diámetro Longitud (pulgada)	Largo Longitud (mm)	Drill Point	PIEZAS/CAJA	CAJA/GRANEL	GRANEL/PALLET	KG/PALLET (G.W.)
8 x 1 1/4	4.2	32	#2	1000	6	40	240
8 x 1 1/2	4.2	38	#2	1000	8	24	192
10 x 1 1/2	4.8	38	#3	1000	4	40	160
10 x 1 5/8	4.8	41	#3	1000	3	40	160
10 x 2	4.8	50	#3	1000	4	24	96
12 x 2 1/2	5.5	63	#3	250	8	24	48
14 x 2 1/2	6.3	63	#4	250	6	24	48
14 x 3	6.3	76	#4	200	6	24	36



SANGALO
DISTRIBUIDOR OFICIAL

PATTA®

AUTOPERFORANTE CABEZA FRESADA PUNTA MECHA (F9)

Aplicaciones

- Mejor opción para la fijación en las ventanas, o en los marcos de las puertas
- El uso en una superficie plana es requerido
- Construcción en seco (Steel Freaming)
- Para punta PH2 X25/X50

Características

- Bordes de corte precisos para mejorar el rendimiento de la perforación
- Acabado zincado Azul
- Punta mecha: taladra directamente el material sin necesidad de taladro previo.



Plated **ZN** **BP** **SS** Point **2** **3**

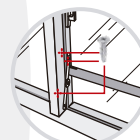

Puntas sugeridas en relación al grosor
punta #2 < 2mm
punta #3 < 5mm

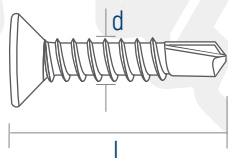
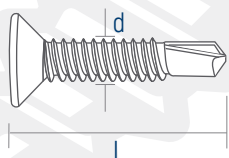

Medida	Díámetro Longitud (pulgada)	Largo Longitud (mm)	Drill Point	PIEZAS/CAJA	CAJA/GRANEL	GRANEL/PALLET	KG/PALLET (G.W.)
8 x 1/2	4.2	12,7	#2	1000	8	40	724
8 x 1	4.2	25	#2	1000	8	40	664
8 x 1 1/4	4.2	32	#2	1000	6	40	611
8 x 1 1/2	4.2	38	#2	1000	8	24	496



SS Stainless Steel
YZ Yellow Zinc
BP Black phosphate
RS Ruspert
ZN Zinc



SANGALO
DISTRIBUIDOR OFICIAL

PATTA®

AUTOPERFORANTE CABEZA FIJADORA PUNTA MECHA (F7)

Aplicaciones

- Lámina de revestimiento al acero
- Estructuras de acero residencial
- Designado para trabajos livianos
- Adecuado para atornillar 1 gruesa y 1 fina placa de acero
- Construcción en seco (Steel Framing)
- Para punta PH3 X25/X50 según medida

Características

- La punta del tornillo no se desliza.
- Acabado zincado azul
- Punta mecha: taladra directamente el material sin necesidad de taladro previo.

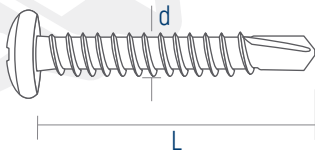

Plated

ZN **SS**

Point

2 **3**

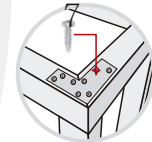

Puntas sugeridas en relación al grosor
punta #2 < 2mm
punta #3 < 5mm

Medida	Diámetro (pulgada)	Longitud (mm)	Largo Longitud (mm)	Drill Point (m/m)	Drill Capacity (m/m)	PIEZAS/CAJA	CAJA/GRANEL	GRANEL/PALLET	KG/PALLET (G.W.)
#6-20 M3.5	3/8"	10		#2	0.5 - 1.0	1000	16	40	569
	1/2"	12,7		#2	0.5 - 1.0	1000	16	40	652
	5/8"	16		#2	0.5 - 1.0	1000	12	40	616
	3/4"	19		#2	0.5 - 1.0	1000	12	40	480
	1"	25		#2	0.5 - 1.0	1000	16	24	384
#8-18 M4.2	1/2"	12,7		#2	1.0 - 2.0	1000	12	40	704
	5/8"	16		#2	1.0 - 2.0	1000	8	40	616
	3/4"	19		#2	1.0 - 2.0	1000	8	40	635
	1"	25		#2	1.0 - 2.0	1000	6	40	586
#10-16 M4.8	1-1/2"	38		#2	1.0 - 2.0	1000	8	24	626
	1"	25		#3	1.0 - 3.0	1000	8	24	628
	1-1/2"	38		#3	1.0 - 3.0	1000	3	40	549



SANGALO
DISTRIBUIDOR OFICIAL

PATTA®

AUTOPERFORANTE CABEZA TROMPETA PUNTA MECHA (F13)

Aplicaciones

- Para el uso de la puntada de yeso cartón de madera al metal
- El uso en una superficie plana es requerido
- Construcción en seco (Steel Framing)
- Para punta PH X25/X50

Características

- Bordes de corte precisos para mejorar el rendimiento del taladro con menor esfuerzo
- Acabado zincado azul
- Punta mecha: taladra directamente el material sin necesidad de taladro previo.

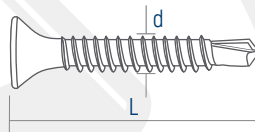

Plated **ZN** **YZ** **SS** Point **3**

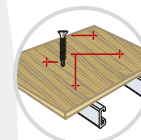
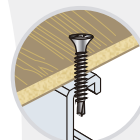

Puntas sugeridas en relación al grosor punta #2 < 2mm

Medida	Diámetro [pulgada]	Longitud [mm]	Drill Point	Largo [mm]	PIEZAS/CAJA	CAJA/GRANEL	GRANEL/PALLET	KG/PALLET (G.W.)
6 x 3/4	3.5	#12	19	1000	24	24	576	
6 x 1	3.5	#12	25	1000	16	24	384	
6 x 1 1/8	3.5	#12	29	1000	16	24	384	
6 x 1 1/4	3.5	#12	32	1000	12	24	288	
6 x 1 1/2	3.5	#12	38	1000	12	24	288	
6 x 1 5/8	3.5	#12	41	1000	8	24	192	
6 x 2	3.5	#12	50	1000	6	24	144	

AUTOPERFORANTE PAN FRAMING PUNTA MECHA (F10)

Aplicaciones

- Optimo resultado en el armado de estructuras livianas en mini perfilarias
- Carpintería aluminio
- Construcción en seco (Steel Framing)
- Para punta PH2 X25/X50

Características

- Punto de ángulo más nítido
- Penetración más rápida
- Mejor capacidad de retención
- Acabado zincado azul
- Punta mecha: taladra directamente el material sin necesidad de taladro previo.



Plated **ZN**

Medida	Longitud [mm]	Diámetro [pulgada]	Longitud Largo [mm]	Drill Point	PIEZAS/CAJA	CAJA/GRANEL	GRANEL/PALLET	KG/PALLET
M3.9 #7	11	7/16"	#2	1000	12	40	15	



SS Stainless Steel **YZ** Yellow Zinc **BP** Black phosphate **RS** Ruspert **ZN** Zinc

TORNILLO FIXER (E2)

Aplicaciones

- Fijación de maderas
- Construcción en seco (Steel Framing)
- Para punta PH2 X25/X50

Características

- Cabeza fresada
- Acabado zincado amarillo
- Ranura Phillips
- Fácil de atornillar
- Alta resistencia a la tracción
- Diferentes opciones de dimensiones y superficies
- Larga vida útil
- Acero cementado y revenido

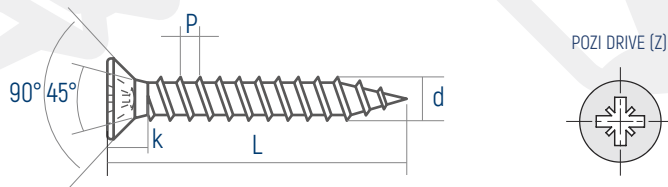

d	dk (max)	k	p	z
M3	5.9	3.20	1	1.35
M3.5	6.9	3.60	2	1.60
M4	7.9	4.25	2	1.80
M4.5	8.9	4.60	2	2.10
M5	9.9	5.20	2	2.20
M6	11.9	6.00	3	2.60



SANGALO
DISTRIBUIDOR OFICIAL

PATTA®



SS
Stainless Steel

YZ
Yellow Zinc

BP
Black phosphate

RS
Ruspert

ZN
Zinc

TORNILLO FIXER (E2)

Medida	Longitud (mm)	PIEZAS/CAJAS	CAJA/GRANEL	GRANEL/PALLET	KG/PALLET
3.0 #4	10	1000	54	24	550
	12	1000	54	24	601
	16	1000	36	24	523
	20	1000	36	24	603
	25	1000	24	24	499
	30	1000	16	24	407
	35	1000	16	24	470
	40	1000	12	24	381
3.5 #6	12	1000	16	40	520
	16	1000	16	40	547
	20	1000	24	24	555
	25	1000	16	24	441
	30	1000	16	24	505
	35	1000	12	24	441
	40	1000	8	24	332
	45	1000	8	24	366
4.0 #8	50	1000	8	24	410
	12	1000	16	40	540
	16	1000	24	24	624
	20	1000	12	40	652
	25	1000	16	24	585
	30	1000	12	24	509
	35	1000	8	24	409
	40	1000	8	24	435
4.5 #9	45	1000	6	24	398
	50	1000	6	24	413
	55	500	8	24	320
	60	500	8	24	334
	70	500	8	24	378
	80	500	8	24	434
	16	1000	16	24	480
	20	1000	16	24	505
4.5 #9	25	1000	12	24	387
	30	1000	12	24	539
	35	1000	8	24	416

Medida	Longitud (mm)	PIEZAS/CAJAS	CAJA/GRANEL	GRANEL/PALLET	KG/PALLET
4.5 #9	40	1000	8	24	563
	45	1000	6	24	470
	50	1000	6	24	516
	55	500	8	24	530
	60	500	8	24	412
	70	500	6	24	367
	80	500	6	24	410
	5.0 #10	25	1000	6	40
30		1000	8	24	562
35		1000	8	24	628
40		1000	6	24	518
45		1000	6	24	473
50		1000	8	24	428
55		500	8	24	450
60		500	8	24	510
6.0 #14	70	500	6	24	435
	80	500	6	24	490
	90	500	6	24	510
	100	250	6	24	540
	110	200	6	24	570
	120	200	6	24	530
	25	1000	6	24	540
	30	1000	6	24	605
6.0 #14	35	500	3	40	608
	40	500	8	24	525
	45	500	8	24	487
	50	500	8	24	435
	55	500	6	24	465
	60	500	6	24	560
	70	250	8	24	438
	80	250	8	24	489
6.0 #14	90	250	8	24	543
	100	250	6	24	450
	110	200	6	24	504
	120	200	6	24	550
	130	200	6	24	570



AUTOPERFORANTE CABEZA TROMPETA PUNTA AGUJA ROSCA GRUESA (F2)

Aplicaciones

- Rosca gruesa: unir paneles de yeso a postes de madera o pernos de metal
- Rosca completa
- Para punta PH2 X25/X50
- Construcción en seco (Steel Framing)

Características

- Ajuste fácil
- Alta resistencia
- Diseño robusto
- Drywall
- Fosfatizado negro

Rosca Gruesa

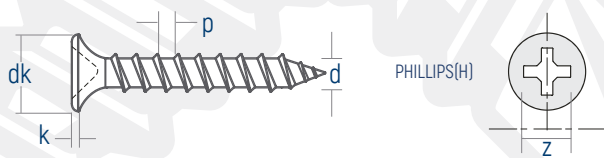

d	dk (max)	k	z	p
M3.5	8-8.4	0.8	No.2	2.82
M4.2	8-8.4	0.8	No.2	3.18
M4.8	8.8-9.2	0.8	No.2	3.18



Medida	Diam.	Long.	PIEZAS/CAJA	CAJA/GRANEL	GRANEL/PALLET
6 x 5/8	3.5	16	1000	24	24
6 x 3/4	3.5	19	1000	12	40
6 x 1	3.5	25	1000	16	24
6 x 1 1/4	3.5	32	1000	12	24
6 x 1 1/2	3.5	38	1000	8	24
6 x 1 5/8	3.5	41	1000	8	24
6 x 1 3/4	3.5	44	1000	6	24
6 x 2	3.5	50	1000	6	24
6 x 2 1/4	3.5	56	500	8	24
6 x 2 1/2	3.5	63	500	8	24
6 x 3	3.5	76	500	6	24
8 x 5/8	4.2	16	1000	16	40
8 x 3/4	4.2	19	1000	12	40
8 x 1	4.2	25	1000	8	40
8 x 1 1/4	4.2	32	1000	6	40
8 x 1 1/2	4.2	38	1000	8	24

Medida	Diam.	Long.	PIEZAS/CAJA	CAJA/GRANEL	GRANEL/PALLET
8 x 1 5/8	4.2	41	1000	6	24
8 x 1 3/4	4.2	44	1000	6	24
8 x 2	4.2	50	1000	6	24
8 x 2 1/4	4.2	56	500	8	24
8 x 2 1/2	4.2	63	500	8	24
8 x 3	4.2	76	500	6	24
10 x 3/4	4.8	19	1000	8	24
10 x 1	4.8	25	1000	6	40
10 x 1 1/4	4.8	32	1000	8	24
10 x 1 1/2	4.8	38	1000	4	40
10 x 1 5/8	4.8	41	500	8	24
10 x 2	4.8	50	500	8	24
10 x 2 1/2	4.8	63	500	6	24
10 x 3	4.8	76	500	6	24
10 x 4	4.8	100	250	8	24



SS
Stainless Steel

YZ
Yellow Zinc

BP
Black phosphate

RS
Ruspert

ZN
Zinc



SANGALO
DISTRIBUIDOR OFICIAL

PATTA®

AUTOPERFORANTE CABEZA TROMPETA PUNTA AGUJA ROSCA FINA (F3)

Aplicaciones

- Rosca fina: Unir paneles de yeso a travesaños metálicos.
- Los tamaños más largos son ideales para capas múltiples o aislamiento
- Para punta PH2 X25/X50

Características

- Ajuste fácil
- Alta resistencia
- Diseño robusto
- Acabado fosfatizado negro

Rosca Fina

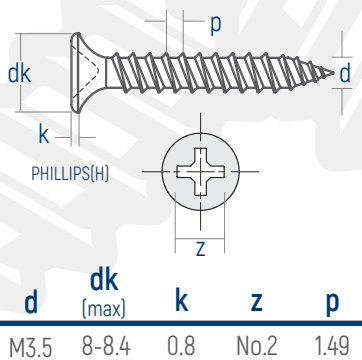

Medida	Diam.	Long.	PIEZAS/CAJA	CAJA/GRANEL	GRANEL/PALLET	GRANEL/PALLET
6 x 5/8	3.5	16	1000	24	24	564
6 x 3/4	3.5	19	1000	12	40	489
6 x 1	3.5	25	1000	16	24	460
6 x 1 1/4	3.5	32	1000	12	24	417
6 x 1 1/2	3.5	38	1000	8	24	326
6 x 1 5/8	3.5	41	1000	8	24	372
6 x 2	3.5	50	1000	6	24	319
6 x 2 1/4	6.0	56	1000	6	24	367
6 x 2 1/2	6.0	63	500	8	24	259

AUTOPERFORANTE PAN FRAMING PUNTA AGUJA (F11)

Aplicaciones

- Para el uso de la puntada de metal al metal
- El uso en una superficie plana es requerido
- Usar en un orificio pretaladrado para la colocación
- Chapa liviana
- Construcción en seco (Steel Framing)
- Para punta PH2 X25/X50

Características

- Acabado zincado azul



Medida	Largo Longitud (mm)	Diámetro Longitud (pulgada)	PIEZAS/CAJA	CAJA/GRANEL	GRANEL/PALLET	KG/PALLET (G.W.)
M3.5 #6	11	7/16"	1000	12	40	15



SANGALO
DISTRIBUIDOR OFICIAL

PATTA®

AUTOPERFORANTE CABEZA FLANGEADA PUNTA AGUJA (F6)

Aplicaciones

- Ampliamente utilizado en materiales de plástico, metal y madera
- Construcción en seco (Steel Framing)
- Para punta PH2 X25/X50

Características

- Acabado zincado azul



d	d2 (max)	h	n (max)
M4.2	11.5	2.6	2

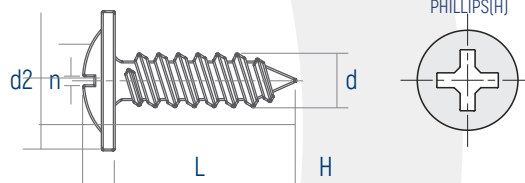

Medida	LONGITUD (mm)	LONGITUD (pulgada)	PIEZAS/CAJA	CAJA/GRANEL	GRANEL/PALLET	KG/PALLET (G.W.)
4.2 x	13	1/2"	1000	8	40	601
	14	9/16"	1000	8	40	630
#8 x	19	3/4"	1000	12	24	644
	25	1"	1000	8	24	498

AUTOPERFORANTE CABEZA HEXAGONAL (T17) RANURADO (F4)

Aplicaciones y Características

- Tipo 17 tornillos cuentan con punta ranurada que permiten una acción de auto perforación en madera, plásticos suaves y superficies de acero en sustratos de madera
- Acabado zincado azul
- Para casquillos Hex magnética - (3/8)
- Arandela de aislación neoprene



Medida	Diam.	Long.	P Tub Hex	PIEZAS/CAJA	CAJA/GRANEL	GRANEL/PALLET	KG/PALLET (G.W.)
14 x 1	6.3	25	3/8	500	6	24	669
14 x 1 1/2	6.3	38	3/8	300	8	24	880
14 x 2	6.3	50	3/8	250	8	24	700
14 x 2 1/2	6.3	63	3/8	200	6	24	716
14 x 3	6.3	76	3/8	200	6	24	684
14 x 3 1/2	6.3	90	3/8	150	6	24	591
14 x 4	6.3	100	3/8	150	6	24	488



SS
Stainless Steel

YZ
Yellow Zinc

BP
Black phosphate

RS
Ruspert

ZN
Zinc

TORNILLO PARKER (E4)

DIN 7981

Aplicaciones

- Para Chapa, carpintería de aluminio, aberturas, cartelería

Características

- Fácil de atornillar
- Alta dureza
- Resistente a altas y bajas temperaturas
- Alto valor de resistencia a la tracción
- Acabado zincado azul

RANURA COMBINADA

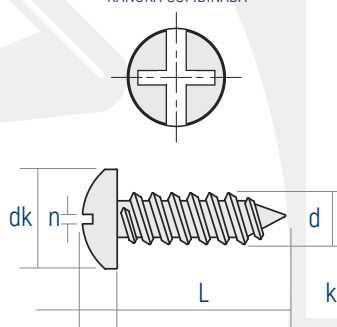

Medida	LARGO LONGITUD (mm)	DIÁMETRO LONGITUD (pulgada)	PIEZAS/CAJA	CAJA/GRANEL	GRANEL/PALLET	KG/PALLET (G.W.)
6 x 3/8	3.5	10	1000	16	24	638
6 x 1/2	3.5	13	1000	16	24	652
6 x 5/8	3.5	16	1000	12	24	616
6 x 3/4	3.5	19	1000	12	24	641
6 x 1	3.5	25	1000	16	24	616
6 x 1 1/4	3.5	32	1000	12	24	576
6 x 1 1/2	3.5	38	1000	8	24	449
6 x 1 3/4	3.5	44	1000	8	24	460
6 x 2	3.5	50	1000	6	24	344
7 x 3/8	3.9	10	1000	16	40	760
7 x 1/2	3.9	13	1000	16	40	795
7 x 5/8	3.9	16	1000	12	40	736
7 x 3/4	3.9	19	1000	12	40	772
7 x 1	3.9	25	1000	8	40	630
7 x 1 1/4	3.9	32	1000	12	24	666
7 x 1 1/2	3.9	38	1000	8	24	521
7 x 1 3/4	3.9	44	1000	8	24	540
7 x 2	3.9	50	1000	8	24	344
7 x 2 1/2	3.9	63	1000	6	24	410
7 x 3	3.9	76	1000	6	24	440
8 x 1/2	4.2	13	1000	12	40	704
8 x 5/8	4.2	16	1000	8	40	616
8 x 3/4	4.2	19	1000	8	40	635
8 x 1	4.2	25	1000	6	40	540
8 x 1 1/4	4.2	32	1000	8	24	540

Medida	LARGO LONGITUD (mm)	DIÁMETRO LONGITUD (pulgada)	PIEZAS/CAJA	CAJA/GRANEL	GRANEL/PALLET	KG/PALLET (G.W.)
8 x 1 1/2	4.2	38	1000	8	24	626
8 x 1 3/4	4.2	44	1000	6	24	562
8 x 2	4.2	50	1000	8	24	423
8 x 2 1/2	4.2	63	1000	8	24	498
8 x 3	4.2	76	1000	6	24	434
10 x 3/8	4.8	10	1000	8	40	700
10 x 1/2	4.8	13	1000	8	40	740
10 x 5/8	4.8	16	1000	8	40	800
10 x 3/4	4.8	19	1000	6	40	654
10 x 1	4.8	25	1000	8	24	628
10 x 1 1/4	4.8	32	1000	4	24	640
10 x 1 1/2	4.8	38	1000	3	40	540
10 x 1 3/4	4.8	44	1000	3	24	549
10 x 2	4.8	50	1000	8	24	541
10 x 2 1/2	4.8	63	1000	6	24	487
10 x 3	4.8	76	1000	8	24	404
12 x 5/8	5.5	16	1000	6	40	700
12 x 3/4	5.5	19	1000	4	40	650
12 x 1	5.5	25	1000	4	40	660
12 x 1 1/4	5.5	32	1000	3	40	783
12 x 1 1/2	5.5	38	1000	8	24	871
12 x 1 3/4	5.5	44	1000	8	24	890
12 x 2	5.5	50	1000	6	24	780
12 x 2 1/2	5.5	63	1000	8	24	465
12 x 3	5.5	76	1000	8	24	541



SANGALO
DISTRIBUIDOR OFICIAL

PATTA®

TORNILLO TANQUE (E3)

Aplicaciones

- Carpintería metálica
- Cartelería publicitaria
- Se utiliza con tuerca, arandela o ambas

Características

- Ranura Combinada- Zincado Azul
- Dimension: ANSI B 18.6.4
- Rosca - UNC - ANSI B 1.1 - BSW : BS84
- Tolerancia 2A
- Especial para chapa
- Acabado zincado azul



LARGO PULGADA	MM	3/16 PIEZAS/CAJA	1/4 PIEZAS/CAJA	5/16 PIEZAS/CAJA
DIAMETRO		3/16	1/4	5/16
HILOS		24	20	18
CABEZA	DIAMETRO	11.38	14.55	17.73
	ALTURA	3	3.81	4.65
3/8	9	12.000/1000	4800/500	
1/2	13	10.000/1000	4500/500	3000/500
5/8	16	8.500/1000	3500/500	2500/500
3/4	19	8.000/1000	3000/500	2500/400
7/8	22	6.000/1000	3000/500	2000/300
1	25	5000/1000	3000/500	2000/300
1 1/4	32	5000/500	3000/300	2000/300
1 1/2	38	4000/500	2100/300	1800/200
1 3/4	44	3500/200	2200/300	1800/200
2	50	3000/200	1800/200	1500/150
2 1/4	56	2500/200	1500/200	1500/100
2 1/2	63	2000/200	1300/200	1300/100
2 3/4	70	1700/200	1100/200	1200/100
3	76	1500/200	1000/200	1000/100
3 1/2	90	1200/100	800/200	800/100
4	100	1000/100	800/150	800/100

RANURA COMBINADA

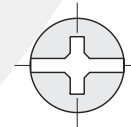

SS
Stainless Steel

YZ
Yellow Zinc

BP
Black phosphate

RS
Ruspert

ZN
Zinc

Puntas y Casquillos

Aplicaciones de Trabajo de Hierro,
Hechas de Acero Aleado

+ Puntas Phillips

Packaging



Material	MEDIDA		PIEZAS/KIT	KIT/CAJA	CAJA/GRANEL	GRANEL/PALLET	KG/PALLET (G.W.)
S2	1/4 X 25mm (PH0 \ PH1 \ PH2 \ PH3	Single end	20	20	4	80	100.90
	1/4 X 50mm (PH0 \ PH1 \ PH2 \ PH3	Single end	10	20	4	80	54.63

⬡ Casquillos Hexagonales Magnéticos

Material	MEDIDA		PIEZAS/SET	SET/CAJA	CAJA/GRANEL	GRANEL/PALLET	KG/PALLET (G.W.)
CR-V	5/16" X 65mm		5	15	4	9	43.56
	3/8" X 65mm		5	15	4	9	47.21
	1/4" X 65mm		5	15	4	9	47.21



AUTOPERFORANTE CABEZA TORX / CONCRETO (F12)

Aplicaciones

- Montaje para aberturas de aluminio sobre hormigón
- Construcción en seco (Steel Framing)
- Para llave TORX

Características

- Adecuado para todos los materiales comunes de construcción y marco sin la necesidad de plugs adicionales (tacos)
- Fácil de atornillar, ahorro de tiempo
- Alta resistencia a la tracción
- Acabado zincado dorado
- Larga vida útil
- Reutilizable

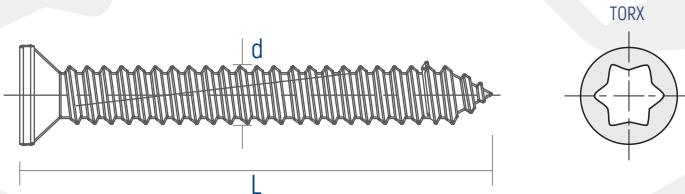

Medida	PIEZAS/CAJA	CAJA/GRANEL	GRANEL/PALLET	KG/PALLET (G.W.)
7.5 x 72	200	8	24	568
7.5 x 112	150	6	24	665



PATEK

— Autoperforante Punta Mecha —

NSSC Acero Inoxidable

Superior anticorrosion

Prueba del spray de sal

5,000-10,000 hrs

Prueba de Kesternich

70 cycles

Alta dureza

615-640 HV

Alta resistencia a la tracción

1,800 Mpa.

Bimetal

- Alta capacidad de perforación y resistencia a la corrosión
- A2-700N en la norma ISO con resistencia garantizada



Alta resistencia

Capacidad de manejo de tornillos autoperforantes

Material del tornillo	Grosor de lámina de acero drivable	Dureza de la punta (HV)		
		200	400	600
PATEK	> 5.5mm*			■
Type 410	> 5.5mm			■
Carbon steel	> 5.5mm			■
Type202	1.6mm		■	
Type304	< 1.6mm		■	

* Perfora laminas de acero de 12mm de grosor....

Alta capacidad de perforación

Tornillo PATEK medida 5.5 con TEK #5

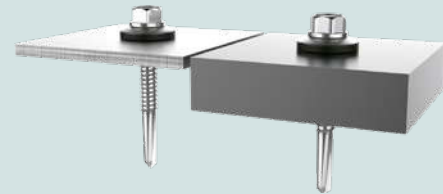

Lamina de acero inoxidable
Grosor 3mm

Lamina de acero
Grosor 12mm

MEDIDA	DIÁMETRO LONGITUD (pulgada)	LARGO LONGITUD (mm)	DRILL POINT	PIEZAS/CAJAS	CAJAS/GRANEL	GRANEL/PALLET	KG/PALLET (G.W.)	
CABEZA HEXAGONAL	#12 M5.5	1	25	#5	500	8	24	555
		1-1/2	38	#5	1000	8	24	574
		2	50	#5	500	6	24	563
		2-1/2	65	#5	250	8	24	444
		3	76	#5	250	6	24	399



SANGALO

DISTRIBUIDOR OFICIAL

PATTA®

PACON

— Tornillo de Anclaje para Hormigón —

Carbon Steel

Mejora de las propiedades mecánicas mediante una técnica de calentamiento especial

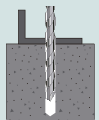

Taladre y limpie la abertura

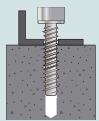

Inserte el anclaje con la llave o el atornillador de impacto

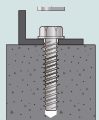

Apriete el anclaje hasta que se mantenga fijo



Features

- Punta de perforación de tres lóbulos con dientes de sierra especial que conduce al hormigón con facilidad (Para NSSC y acero al carbono)
- Alta dureza. Fuerte resistencia a la tracción
- No se transfiere ninguna extensión al material base evitando una instalación compleja
- Aplicable más cerca del borde que los anclajes de expansión tradicionales
- Mantenimiento sencillo- Desmontable y Extraíble
- Rendimiento fiable en hormigón fisurado o sin fisuras

Medida	Longitud (mm)	PIEZAS/CAJA	CAJA/GRANEL	GRANEL/PALLET	KG/PALLET (G.W.)
M6 #	50	250	8	24	587
	75	200	6	24	494
M8 #	75	100	8	24	577
	100	100	6	24	501
M10 #	75	50	8	24	554
	100	50	4	40	572
M12 #	100	50	3	40	720
	150	25	4	40	587



SANGALO

DISTRIBUIDOR OFICIAL

PATTA®



Madera con acero ligero y resistente
**AUTOPERFORANTE CABEZA HEXAGONAL
 TIPO 17 RANURADO CON ARANDELA EPDM**



Techado y revestimiento
 con madera

**AUTOPERFORANTE CABEZA
 HEXAGONAL CON
 ARANDELA
 VULCANIZADA
 PUNTA MECHA**



Techado y revestimiento
 con acero ligero

**AUTOPERFORANTE CABEZA
 FLANGEADA PUNTA MECHA**



Techado y revestimiento
 con acero resistente

**AUTOPERFORANTE CABEZA
 HEXAGONAL CON ARANDELA
 VULCANIZADA PUNTA MECHA**



Fijación al hormigón

**AUTOPERFORANTE
 CABEZA TORX / CONCRETO**



Techado y revestimiento de madera
TORNILLO FIX



Techado y revestimiento más
 embarque con acero ligero

**AUTOPERFORANTE CABEZA
 TROMPETA
 PUNTA AGUJA ROSCA FINA DURLOCK**

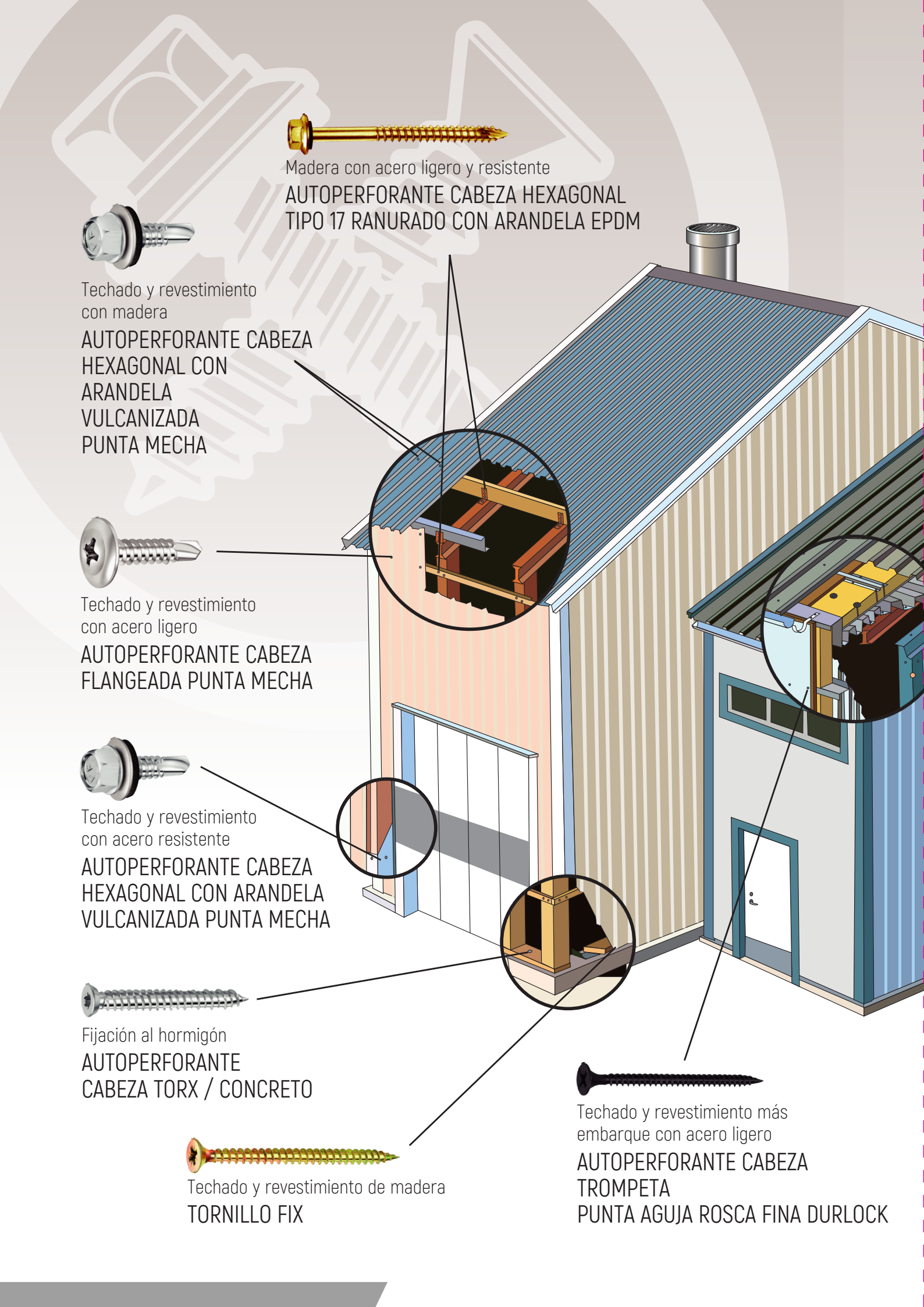

AGENTE EXCLUSIVO EN ARGENTINA:

PATTA[®]
AUTOPERFORANTES

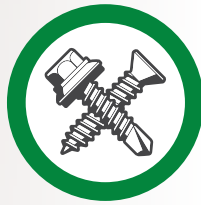

SANGALO



Techado y revestimiento con acero resistente
**AUTOPERFORANTE PARKER CABEZA
FIJADORA PUNTA MECHA**



Panel emparedado con acero ligero
**AUTOPERFORANTE CABEZA HEXAGONAL
TIPO 17
RANURADO CON ARANDELA EPDM**



**AUTOPERFORANTE
CABEZA FRESADA
PUNTA MECHA**



**AUTOPERFORANTE
PAN FRAMING
PUNTA MECHA**



**AUTOPERFORANTE
CABEZA FLANGEADA
PUNTA AGUJA**



Fijación al hormigón
**AUTOPERFORANTE
CABEZA TORX / CONCRETO**

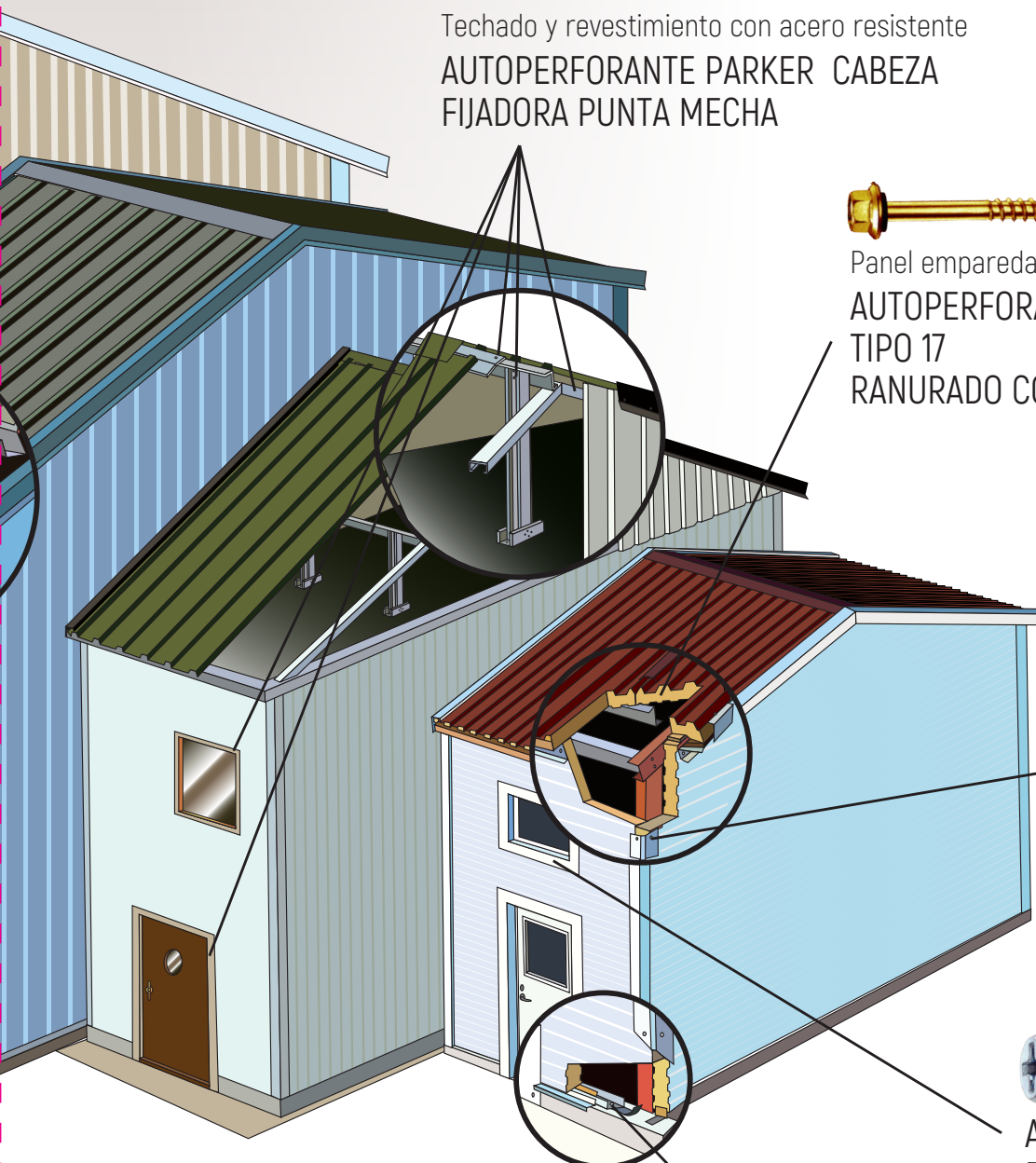



SANGALO

DISTRIBUIDOR OFICIAL

PATTA®